

High-sensitivity and low cost vibration sensor

Vibration detection using unique shape of sensor and amount of changing high frequency impedance

Overview

So far, the laser doppler vibrometer or the accelerometer using microelectromechanical system is known to be the most high sensitive vibrometer with actual technology. However, many vibrometers can't be used in one object due to its high cost. On the other hand, the strain gauge is known to be cheap but the sensitivity is not enough high in order to detect abnormal vibration.

This invention has focus on bending a magnetic material can generate a high sensitive permeability variation where it can be detected as HF impedance variation, and the shape of cantilever. This invention can provide high-sensitivity vibration sensor at low cost.

Effect · Application

<Effect> High sensitive vibration sensing

- < Application >
- Vibration spectrum measurement
 - Soundness diagnostic of social infrastructure such as bridge or tunnel

IP Data

IP No. : JP 7075110
 Inventor : ISHIYAMA Kazushi
 Admin No. : T17-103

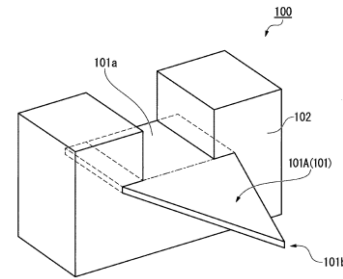

100.Vibration sensor 101.Cantilever 101A.Easy bending area 101a.Built-in edge 101b.Free edge 102.Support 103.Base material 104.Bending sensor 105.Magnetostriction layer 106.Conductor layer 108.Wiring C.Axis E.Extending L.Layer T.Thickness

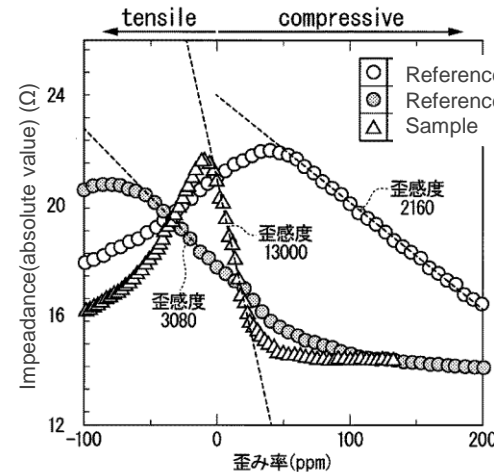
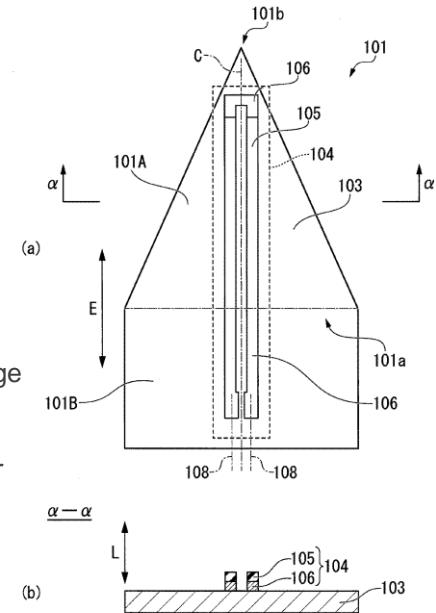

[Up left] Squint view of this invention
[Up right] Ground plan and cross section of cantilever equipped with this invention
[Down left] Impedance results (absolute value) against the magnetostriction layer's bending value of this vibration sensor

Contact

Download OnePager



Contact

<https://www.t-technoarch.co.jp/en/contact.html>



Check Out Our Inventions

<https://www.t-technoarch.co.jp/en/anken.php>



Follow us

<https://www.linkedin.com/company/tohoku-techno-arch>



Leading you to Successful Industrialization



TOHOKU TECHNO ARCH

株式会社 東北テクノアーチ