

# Inducer with slit

Simple configuration suppresses cavitation instability

## Overview

In a high-speed rotary pump such as used in a turbo pump for a rocket engine, cavitation occurs at the pump inlet. Therefore, a spiral auxiliary impeller with excellent suction performance called an inducer is installed in front of the pump main impeller to boost and transport stable liquid. Various techniques have been proposed to suppress unstable and asymmetric phenomena associated with cavitation in the inducer. However, conventional techniques have problems such as difficulty in machining, increased axial vibration and weight.

The present invention has attempted to solve the above problems by providing a slit (notch) in the inducer and optimizing the conditions of the position, depth and width of the slit. Specifically, it has the following features.

- Provide axisymmetric slits on each blade of the inducer
  - A slit is provided upstream from the throat entrance on the outer peripheral side of the blade.
  - The inside length of the slit in the radial direction is shorter than the opening width, and the shape is wider.
- With this configuration, it is possible to suppress the instability phenomenon while maintaining the step-up performance of the inducer.

## Product Application

- Turbo pump for rocket engine
- High-speed rotary turbopumps such as pumps for liquefied natural gas and liquid hydrogen

## IP Data

IP No. : JP2023-67131  
 Inventor : IGA Yuka, KAWASAKI Satoshi  
 Admin No. : T21-050

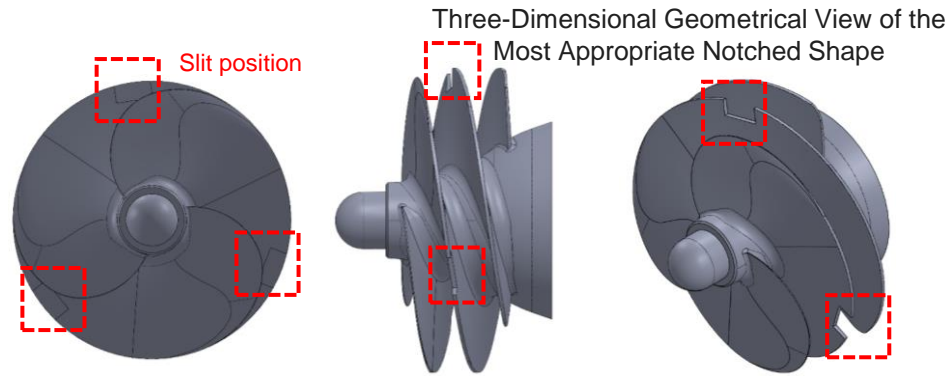

A slit condition was found to suppress the occurrence of cavitation

● is able to completely suppress asymmetric cavitation

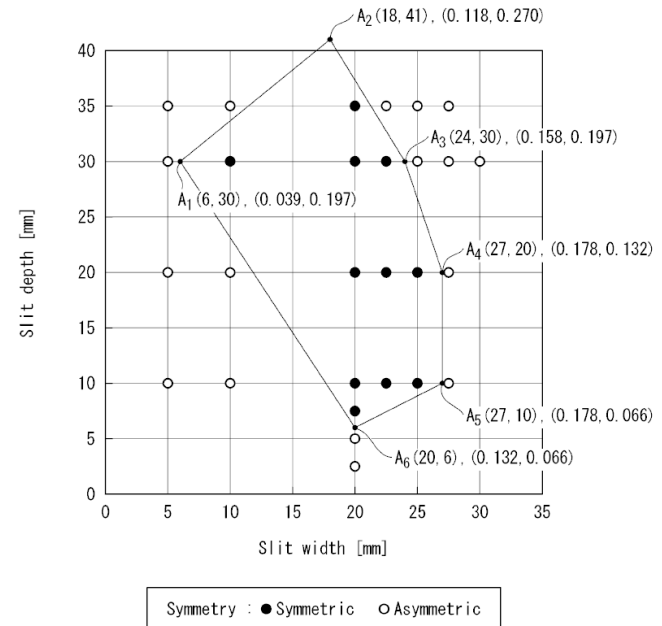

## Contact

Download OnePager



Contact

<https://www.t-technoarch.co.jp/en/contact.html>



Check Out Our Inventions

<https://www.t-technoarch.co.jp/en/anken.php>



Follow us

<https://www.linkedin.com/company/tohoku-techno-arch>



# Leading you to Successful Industrialization



**TOHOKU TECHNO ARCH**

株式会社 東北テクノアーチ